

Universal Heavy-Duty Equipment Stands with Casters

HC-24 HC-36 HC-48 HC-60 HC-72



FEATURES

- Stainless steel top with 1" (25 mm) lip on back edge
- Adjustable, stainless steel bottom shelf
- Stainless steel legs with casters

DESCRIPTION

The HC series equipment stands are built to last. These stands come in a range of widths from 24" to 72" to accommodate diverse equipment sizes. Features include a stainless steel top shelf and an stainless steel bottom shelf that can be adjusted to any height. Models also come with stainless steel legs with casters. Field assembly required.

HEAVY DUTY EQUIPMENT STANDS with CASTERS

MODEL	WIDTH in. [mm]	DEPTH in. [mm]	HEIGHT in. [mm]	SHIP WEIGHT lbs. [kg]	STAND RATED FOR lbs. [kg]	FREIGHT CLASS
HC-24	24 [610]	30.5 [775]	24 [610]	25 [11.3]	500 [226.8]	85
HC-36	36 [914]	30.5 [775]	24 [610]	68 [30.8]	500 [226.8]	85
HC-48	48 [1219]	30.5 [775]	24 [610]	88 [40.0]	700 [317.5]	85
HC-60	60 [1524]	30.5 [775]	24 [610]	105 [47.6]	850 [385.6]	85
HC-72	72 [1829]	30.5 [775]	24 [610]	122 [55.3]	1000 [453.6]	85

WARRANTY

These units come with a one [1] year warranty for parts and labor.

STAR HOLDINGS GROUP

265 Hobson St. • Smithville, TN 37166
 Telephone: 800 264 7827
 www.starholdingsgrp.com

Printed in the U.S.A. • 2M-Z26036 REV - (01-24)
 Specifications are subject to change without notice
 and are not intended for installation purposes.

Universal Heavy-Duty Equipment Stands with Casters

☐ HC-24 ☐ HC-36 ☐ HC-48 ☐ HC-60 ☐ HC-72

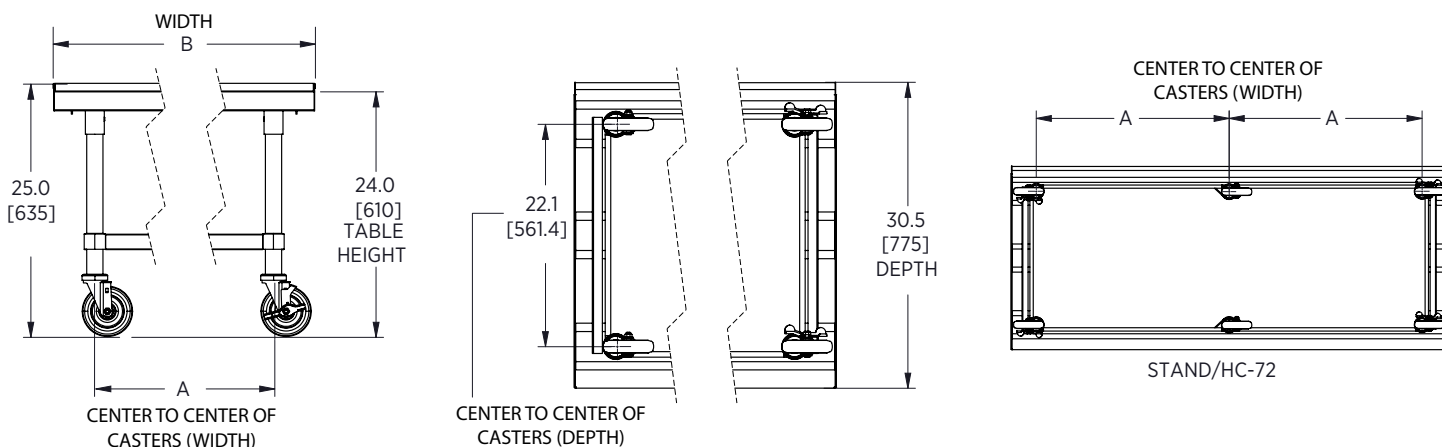

DIM. A CENTER TO CENTER OF CASTERS (WIDTH)	DIM. B OVERALL WIDTH OF CART	LOCKING CASTER	NON-LOCKING CASTER
16.10 (408.94)	24.12 (612.65)	2	2
28.10 (713.74)	36.12 (917.45)	2	2
31.05 (788.67)	48.12 (1222.25)	2	2
40.10 (1018.54)	60.12 (1527.05)	2	2
52.10 (1323.34)	72.12 (1831.85)	4	2

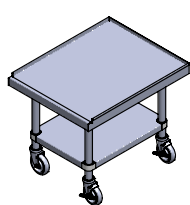

8L-STAND/HC-24

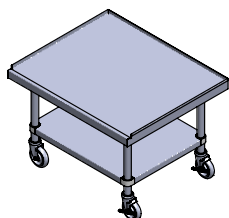

8L-STAND/HC-36

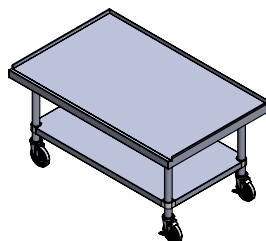

8L-STAND/HC-48

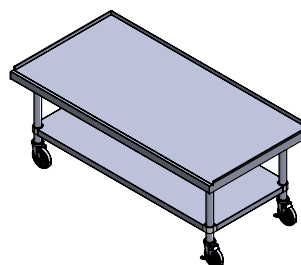

8L-STAND/HC-60

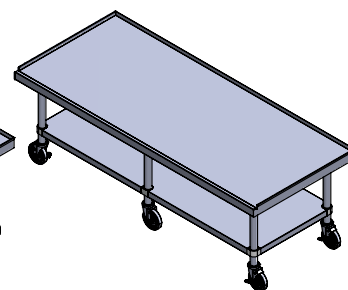

8L-STAND/HC-72

Due to periodic changes in designs, methods, procedures, policies and regulations, the specifications contained in this sheet are subject to change without notice. While Star Manufacturing exercises good faith efforts to provide information that is accurate, we are not responsible for errors or omissions in information provided or conclusions reached as a result of using the specifications. By using the information provided, the user assumes all risks in connection with such use.

STAR HOLDINGS GROUP

265 Hobson St. • Smithville, TN 37166
Telephone: 800 264 7827
www.starholdingsgrp.com

Printed in the U.S.A. • 2M-Z26036 REV - (01-24)
Specifications are subject to change without notice
and are not intended for installation purposes.